

CarbonWeb® VMP-X

CarbonWeb® VMP-X v-bank mini pleat is an exceptionally high-quality industrial grade HVAC molecular air filter specifically designed to remove and mitigate diesel exhaust and aviation fuel fumes entering a buildings HVAC system from an outside source. Typical applications include helipads, loading docks, airports, construction sites and HVAC systems located near freeways or heavy traffic areas.

VMP-X is constructed with a very heavy and dense 600 gsm weight proprietary blend media of various high activity carbons, impregnated carbons and impregnated activated alumina especially designed to react with and help remove lower concentrations of the multiple harmful gases generated by diesel and aviation fuel combustion such as NOx, formaldehyde and carbon monoxide.

The heavyweight CarbonWeb® media is manufactured via D-Mark's patented thermo-bonding process using exceptionally fine 20x50 mesh carbons and activated alumina. Heavy media constructed with fine mesh granules greatly increases surface area and dwell time required to capture harmful gases with high first-pass efficiency. All CarbonWeb media is designed and manufactured in the USA to exacting standards.



CarbonWeb VMP-X is constructed with very heavyweight 600 gsm media specifically designed to remove and mitigate diesel and aviation fuel exhaust fumes entering HVAC systems

Helipads and Helidecks - Hospital & Private
Loading Dock Fumes from Idling Trucks
Airports
Occupied Buildings Near Active
Construction Sites with Combustion Engines
Universities
Buildings with Air Intakes Near Freeways and
High Traffic Areas

Model	Nominal Size	High Activity Carbon	Weight Each	Initial Resistance WC	Initial MERV	Final Resistance WG
CarbonWeb VMP-X				500 FPM		
VMPX-12-100-01	12x24x12	600 gsm	9.0 LBS	0.29"	8	1.5"
VMPX-12-100-06	20x24x12	600 gsm	13.2 LBS	0.29"	8	1.5"
VMPX-12-100-08	24x24x12	600 gsm	16.0 LBS	0.29"	8	1.5"

CarbonWeb® VMP-X

RENSA FILTRATION

CarbonWeb® VMP-X

Performance Data

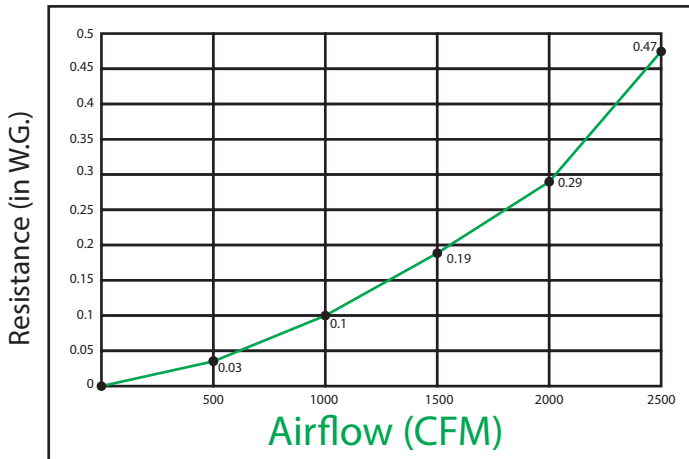

Specifications

Media: 600 gsm proprietary blend carbons and activated alumina 20x50 fine-mesh granules suspended in a nonwoven matrix.

Frame: Double walled high strength plastic v-design frame for industrial applications with minimum resistance to air flow.

Sealant: Media pack shall be bonded to frame utilizing moisture resistant adhesive for continuous seal.

Gasketing: Optional premium closed cell neoprene gasketing available.

Maximum Operating Temp: 140F.

Incinerable: Yes

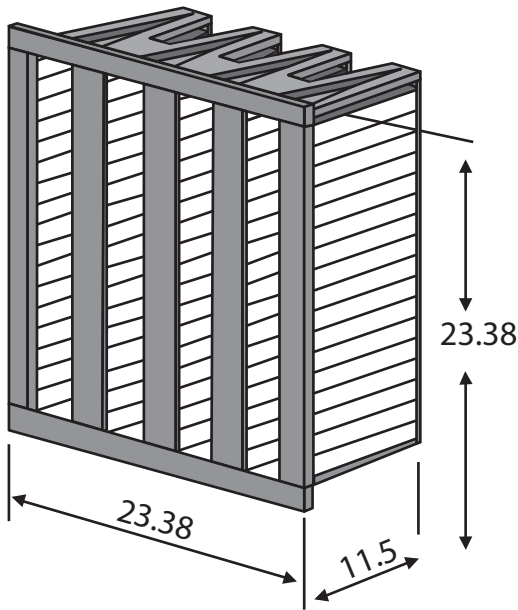

Industrial Grade Plastic Frame with Double Wall Construction

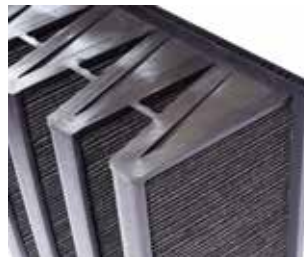

Engineered Design Maximizes Air-Flow and Filter Strength with Reduced Weight



Precision Pleating for Optimum Surface Area and Increased Dwell Time



Diesel Exhaust



Helipads



Airports



High Traffic